





# HITCH Specification Form

PLEASE FULLY COMPLETE THE FOLLOWING AND THEN **SEND BY EMAIL.**

COMPANY DETAILS			
COMPANY NAME		CONTACT	
TELEPHONE		FAX	
EMAIL ADDRESS		DATE	

DETAILS OF CUSTOMERS PARENT MACHINE			
MANUFACTURER		MACHINE GROSS WEIGHT	
MODEL NAME		TWO WAY ATTACHMENT CIRCUIT	YES / NO
YEAR MADE		THIRD FREE FLOW RETURN TO TANK LINE	YES / NO

MAXIMUM PRESSURE AT THE ATTACHMENT LINE (BOTH DIRECTIONS)		PSI	PSI
MAXIMUM FLOW AT THE ATTACHMENT LINE (BOTH DIRECTIONS)		US GPM	US GPM

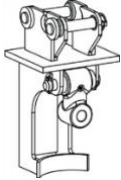
LINKAGE REQUIREMENTS		
SINGLE PIN HITCH		INSERT AN X FOR YES ( )
DOUBLE PIN HITCH		INSERT AN X FOR YES ( )
DOUBLE PIN CRADLE HITCH		INSERT AN X FOR YES ( )

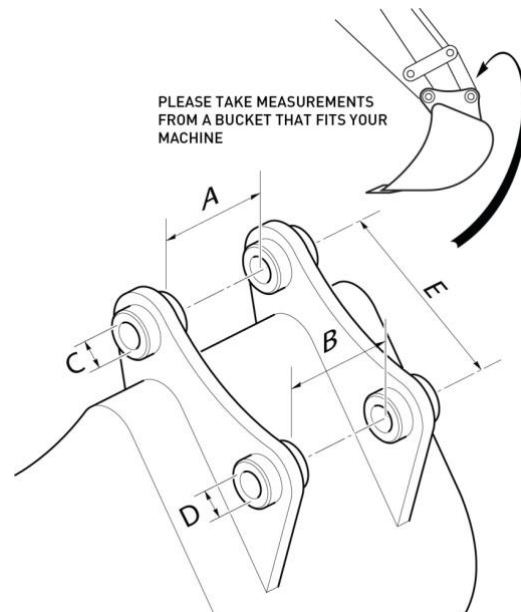

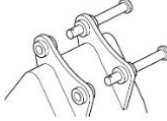
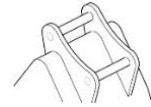
MEASUREMENTS (INCHES)				
DIPPER WIDTH (A)		inches	<b>LOOSE PIN BUCKET</b> 	INSERT AN X FOR YES ( )
LINK WIDTH (B)		inches		
DIPPER PIN DIAMETER (C)		inches		
BUCKET RAM PIN DIAMETER (D)		inches		
BUCKET PIN CENTRES (E)		inches	<b>FIXED WELDED PIN BUCKET</b> 	INSERT AN X FOR YES ( )
ADDITIONAL NOTES				

PLEASE EMAIL TO [SALES@SOLARISATTACHMENTS.COM](mailto:SALES@SOLARISATTACHMENTS.COM)